

| REVISIONS |             |      |          |
|-----------|-------------|------|----------|
| REV       | DESCRIPTION | DATE | APPROVED |
|           |             |      |          |

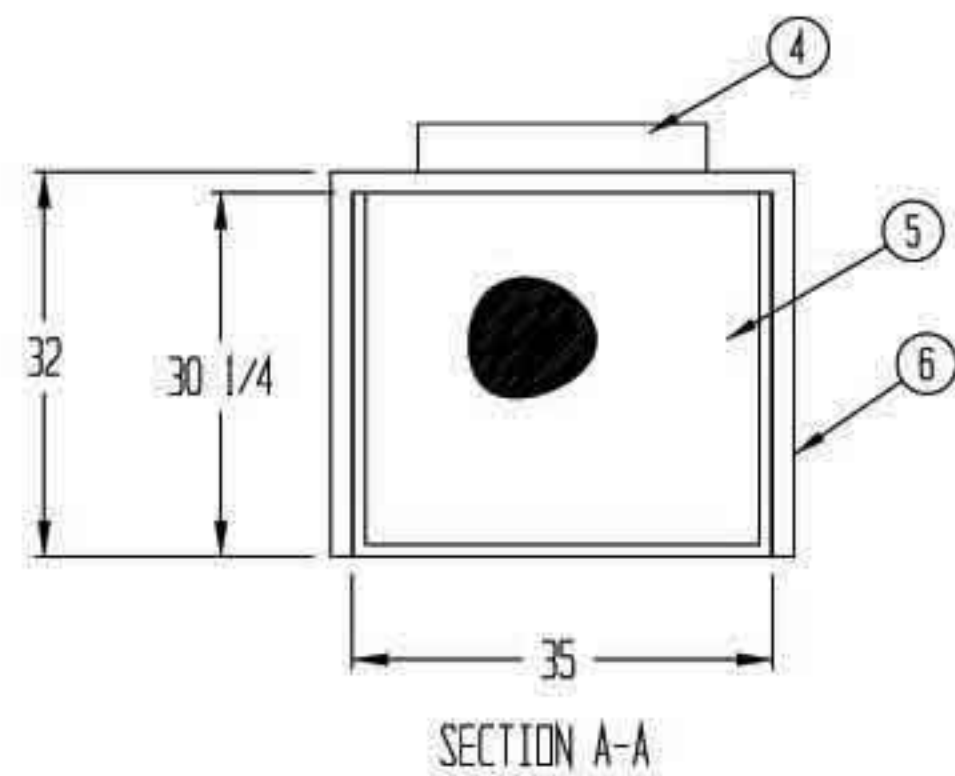

CONSTRUCTION:

- FILTER MODULE TO BE CONSTRUCTED OF 16 GA. WHITE EPOXY PAINTED STEEL
- WORK PLENUM TO BE CONSTRUCTED OF 16 GA. WHITE EPOXY PAINTED STEEL
- FRAME TO BE CONSTRUCTED OF 1 3/4 X 1 3/4 X 14 GA. TUBULAR PAINTED STEEL
- UNIT TO MEET ISO STANDARD 14644-1 AND FED. STD. 209E FOR CLASS 100 DEVICES
- ELECTRICAL WIRING TO CONFORM LATEST NEC STANDARDS
- ELECTRICAL REQUIREMENT: 115 VOLT/ 60HZ/ 15A

- ① 1 EA. 30 X 12 ANODIZED ALUMINUM PRE-FILTER GRILL WITH DISPOSABLE 35% EFF PRE-FILTER
- ② CONTROL PANEL WITH BLOWER AND LIGHT SWITCHES AND MINIHELIC GAUGE
- ③ 1/4" CLEAR POLYCARBONATE SIDE PANELS,
- ④ 4" X 24" WHITE ALUMINUM EXHAUST DUCT
- ⑤ 6" EXHAUST PLENUM WITH PERFORATED STAINLESS STEEL WORK SURFACE
- ⑥ TUBULAR PAINTED STEEL FRAME
- ⑦ 1 EA. 9-9A DIRECT DRIVE MOTOR BLOWER WITH 1/3 H.P. HIGH EFFICIENCY 115 VOLT MOTOR, CAPABLE OF PRODUCING 750 CFM AT 1.2" S.P.
- ⑧ 1 EA. 30 X 36 X 3 1/2 ANODIZED ALUMINUM FRAMED HEPA FILTER. 99.99% EFFECTIVE ON PARTICLES OF 0.3 MICRONS IN SIZE WITH 2 PLUGGED PORTS
- ⑨ 2 EA. F25T8 FLUORSCENT LAMPS, 115V/ 60HZ
- ⑩ ELECTRICAL POWER CORD FOR CUSTOMER WITH 115V/60HZ/15A PLUG
- ⑪ HINGED 1/4" CLEAR POLYCARBONATE FACE SHIELD
- ⑫ 20 GA. EPOXY PAINTED STEEL REAR PANEL
- ⑬ ADJUSTABLE RETURN AIR DAMPER

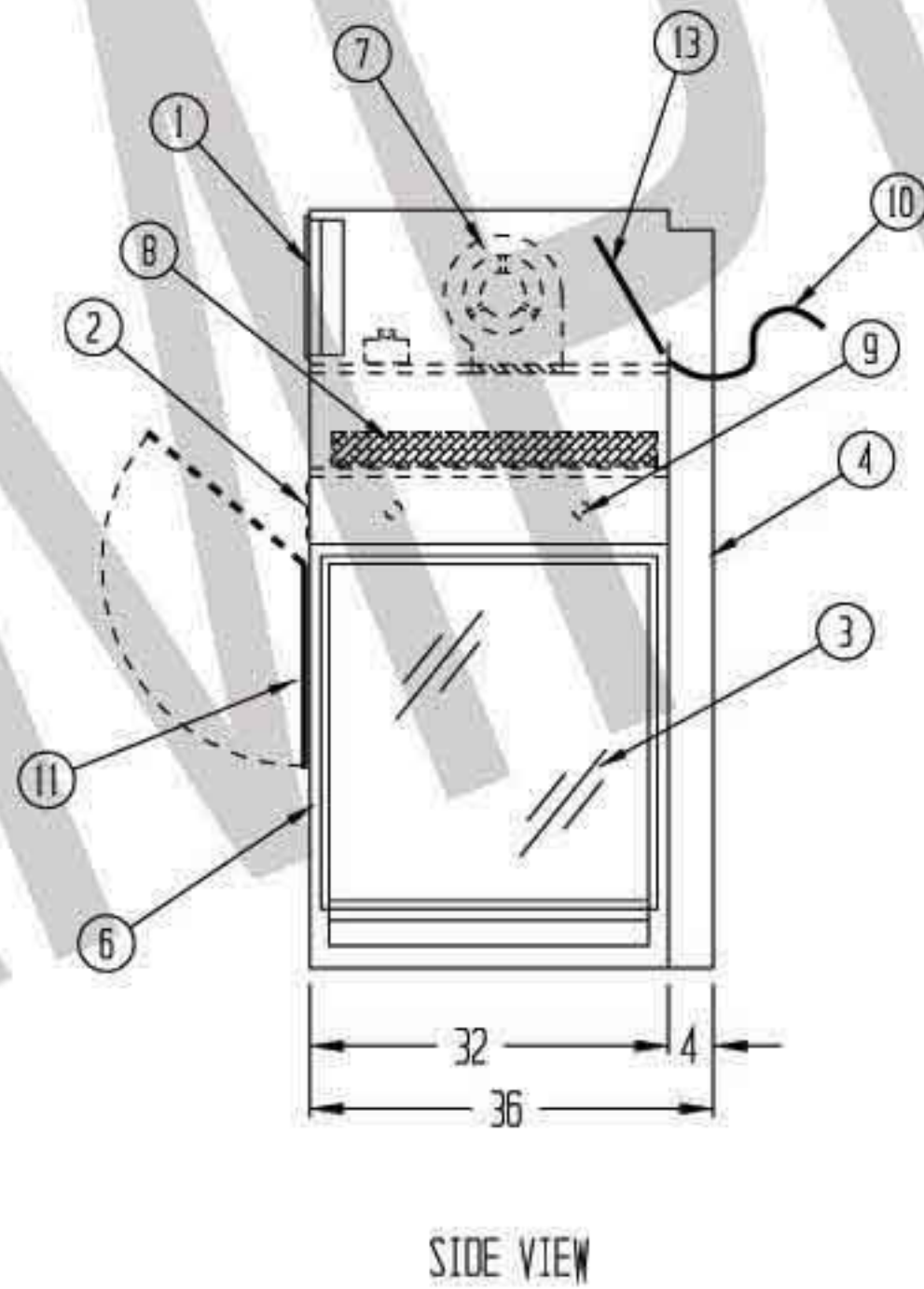
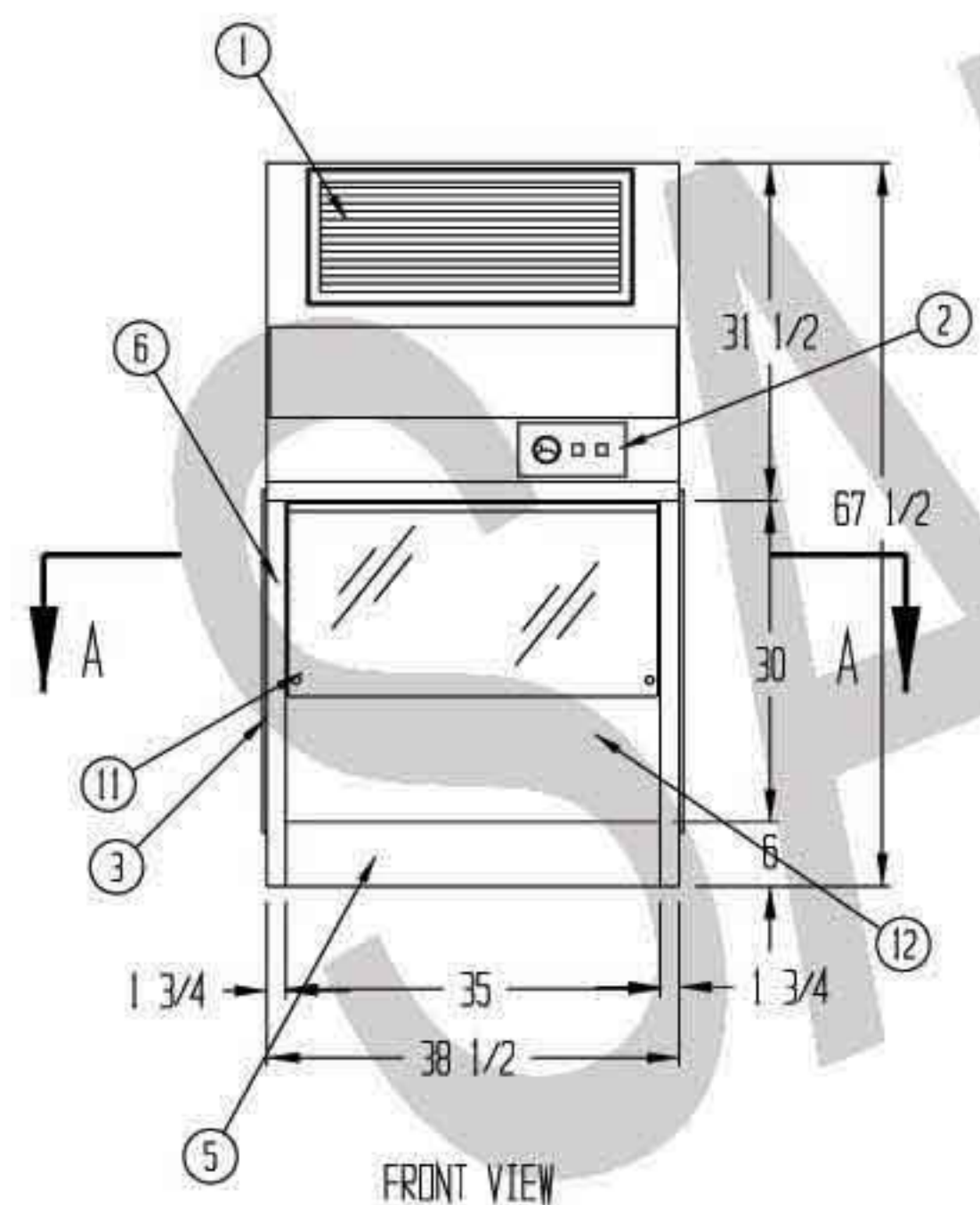

|             |    |  |               |         |               |
|-------------|----|--|---------------|---------|---------------|
| DRAWN FOR   |    | <b>HALCO PRODUCTS CO.</b>                  |               |         |               |
|             |    | 100 NO. GORDON STREET ELK GROVE, IL. 60007 |               |         |               |
|             |    | TITLE<br>CAT3302-TT/PR/ST                  |               |         |               |
| DRAWN BY    | TM | SIZE                                       | JOB NO. ----- | QTY NO. | 1915115BHALCO |
| APPROVED BY |    | SCALE                                      | 1/2" = 1'-0"  | DATE    | 2-3-10        |
|             |    |  |               | SHEET   |               |